

# Absolute-pressure sensors in micromechanical hybrid design

Measurement of pressures in gases up to 400 kPa

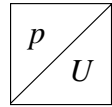

- High accuracy.
- EMC protection better than 100 V m<sup>-1</sup>.
- Temperature-compensated.
- Version with additional integral temperature sensor.



## Applications

This sensor is used to measure the absolute intake-manifold pressure. On the version with integral temperature sensor, the temperature of the drawn-in air flow is also measured.

## Design and function

The piezoresistive pressure-sensor element and suitable electronic circuitry for signal-amplification and temperature compensation are mounted on a silicon chip. The measured pressure is applied from above to the diaphragm's active surface. A reference vacuum is enclosed between the rear side and the glass base. Thanks to a special coating, both pressure sensor and temperature sensor are insensitive to the gases and liquids which are present in the intake manifold.

## Installation information

The sensor is designed for mounting on a horizontal surface of the vehicle's intake manifold. The pressure fitting together with the temperature sensor extend into the manifold and are sealed-off to atmosphere by O-rings. By correct mounting in the vehicle (pressure-monitoring point on the top at the intake manifold, pressure fitting pointing downwards etc.) it is to be ensured that condensate does not collect in the pressure cell.

## Range

Pressure range kPa (p <sub>1</sub> ...p <sub>2</sub> )	Characteristic curve <sup>1)</sup>	Features	Dimension drawing <sup>2)</sup>	Order No.
10...115	1		1	<b>B 261 260 136<sup>3)</sup></b>
10...115	1		2	<b>0 261 230 052</b>
20...250	1		1	<b>0 281 002 487</b>
10...115	1	Integral temperature sensor	3	<b>0 261 230 030</b>
20...250	1	Integral temperature sensor	3	<b>0 261 230 042</b>
20...300	1	Integral temperature sensor	3	<b>0 281 002 437</b>
50...350	2	Integral temperature sensor	3	<b>0 281 002 456</b>
50...400	2	Integral temperature sensor	3	<b>B 261 260 508<sup>3)</sup></b>

<sup>1)</sup> The characteristic-curve tolerance and the tolerance expansion factor apply for all versions, see Page 36

<sup>2)</sup> See Page 37

<sup>3)</sup> Provisional draft number, order number available upon enquiry. Available as from about the end of 2001

## Accessories

Accessories	Qty. required:	Order No.
Plug housing	1 <sup>4)</sup>	<b>1 928 403 966</b>
Plug housing	1 <sup>5)</sup>	<b>1 928 403 736</b>
Contact pin	3 or 4 <sup>6)</sup>	<b>1 928 498 060</b>
Individual gasket	3 or 4 <sup>6)</sup>	<b>1 928 300 599</b>

<sup>4)</sup> Plug housing for sensors without integral temperature sensor

<sup>5)</sup> Plug housing for sensors with integral temperature sensor

<sup>6)</sup> Sensors without temperature sensor each need 3 contacts and gaskets. Sensors with integral temperature sensor each need 4 contacts and gaskets

**Technical data**

			min.	typ.	max.
Operating temperature	$\vartheta_B$	°C	-40	-	+130
Supply voltage	$U_V$	V	4.5	5.0	5.5
Current consumption at $U_V = 5\text{ V}$	$I_V$	mA	6.0	9.0	12.5
Load current at output	$I_L$	mA	-1.0	-	0.5
Load resistance to $U_V$ or ground	$R_{\text{pull-up}}$	k $\Omega$	5	680	-
	$R_{\text{pull-down}}$	k $\Omega$	10.0	100	-
Response time	$t_{10/90}$	ms	-	1.0	-
Voltage limitation at $U_V = 5\text{ V}$					
Lower limit	$U_{A\text{ min}}$	V	0.25	0.3	0.35
Upper limit	$U_{A\text{ max}}$	V	4.75	4.8	4.85

**Limit data**

Supply voltage	$U_{V\text{ max}}$	V	-	-	+16
Storage temperature	$\vartheta_L$	°C	-40	-	+130

**Temperature sensor**

Measuring range	$\vartheta_M$	°C	-40	-	+130
Measured current	$I_M$	mA	-	-	1 <sup>1)</sup>
Nominal resistance at +20 °C		k $\Omega$	-	2.5±5%	-
Thermal time constant	$t_{63}$	s	-	-	10 <sup>2)</sup>

<sup>1)</sup> Operation at 5 V with 1 k $\Omega$  series resistor

<sup>2)</sup> In air with a flow rate of 6 m·s<sup>-1</sup>

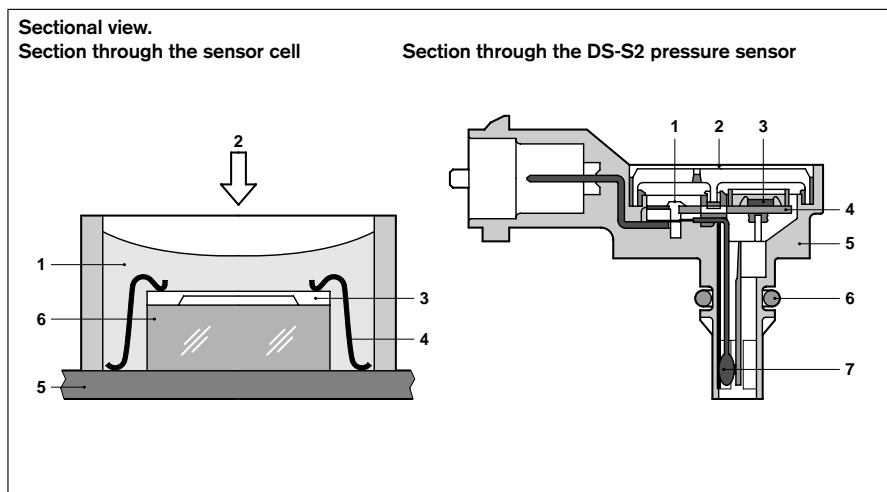

**Section through the sensor cell.**

1 Protective gel, 2 Pressure, 3 Sensor chip, 4 Bonded connection, 5 Ceramic substrate, 6 Glass base.

**Section through the pressure sensor.**

1 Bonded connection, 2 Cover, 3 Sensor chip, 4 Ceramic substrate, 5 Housing with pressure-sensor fitting, 6 Gasket, 7 NTC element.

**Signal evaluation: Recommendation.**

R Reference  
D Pressure signal  
T Temperature signal

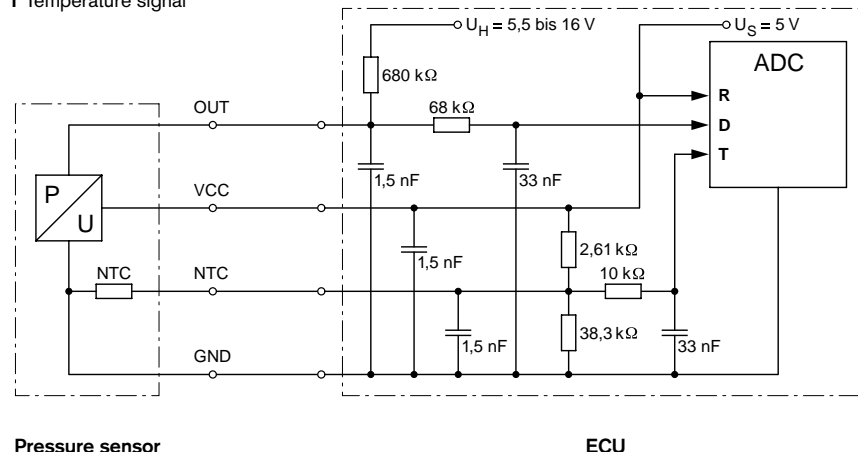

**Signal evaluation: Recommendation.**

The pressure sensor's electrical output is so designed that malfunctions caused by cable open-circuits or short circuits can be detected by a suitable circuit in the following electronic circuitry. The diagnosis areas situated outside the characteristic-curve limits are provided for fault diagnosis. The circuit diagram shows an example for detection of all malfunctions via signal outside the characteristic-curve limitation.

**Absolute-pressure sensors in micromechanical hybrid design (contd.)**  
**Measurement of pressures in gases up to 400 kPa**

**Characteristic curve 1 ( $U_V = 5.0\text{ V}$ ).**

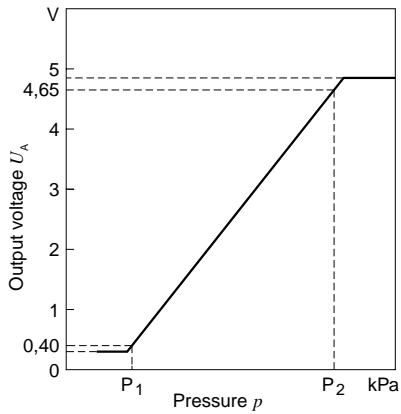

**Characteristic curve ( $U_V = 5.0\text{ V}$ ).**

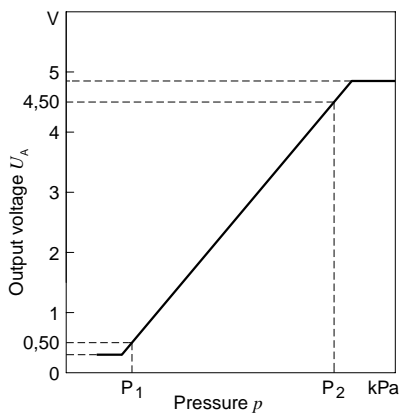

**Characteristic-curve tolerance.**

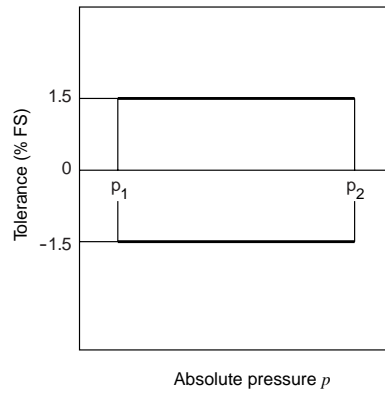

**Tolerance-expansion factor.**

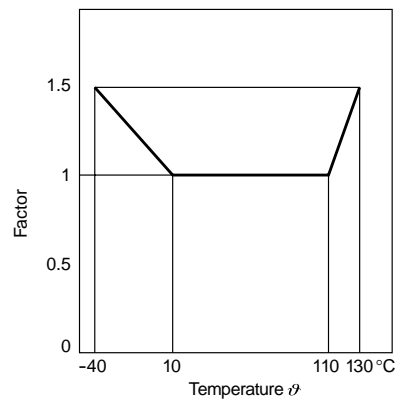

**Temperature-sensor characteristic curve.**

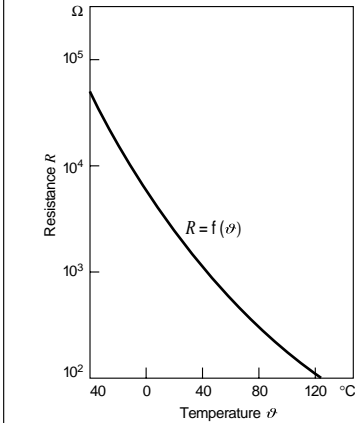

**Explanation of symbols.**

- $U_A$  Output voltage
- $U_V$  Supply voltage
- $k$  Tolerance multiplier
- D After continuous operation
- N As-new state

**Dimensions drawings.**

- ①  
 Connector-pin assignment  
 Pin 1 +5 V  
 Pin 2 Ground  
 Pin 3 Output signal

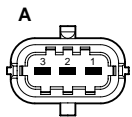
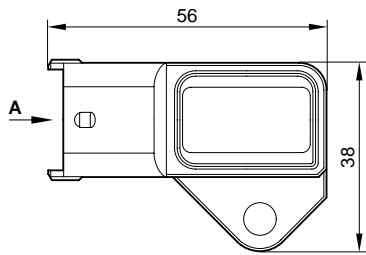
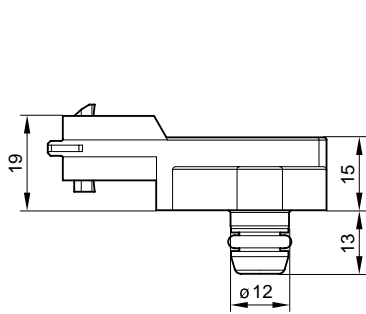

- ②  
 Connector-pin assignment  
 Pin 1 +5 V  
 Pin 2 Ground  
 Pin 3 Output signal

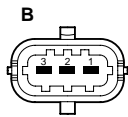
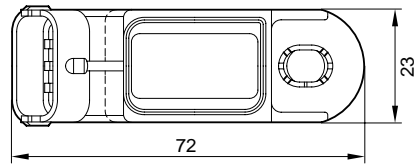
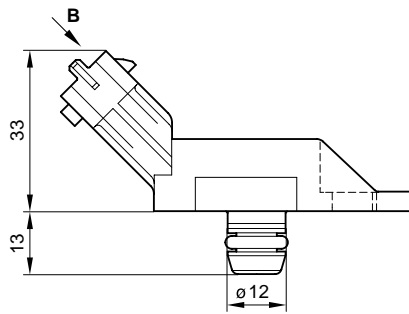

- ③  
 Connector-pin assignment  
 Pin 1 Ground  
 Pin 2 NTC resistor  
 Pin 3 +5 V  
 Pin 4 Output signal

